

830-850nm 3-port Optical Circulator

FEATURES

- High Isolation
- Low Insertion Loss
- Epoxy-Free Optical Path
- High Reliability and Stability
- Low Profile Packaging

APPLICATIONS

- Fiber Optic Amplifiers
- Fiber Optic Instruments
- WDM Systems
- Dispersion Compensation
- Light Routing

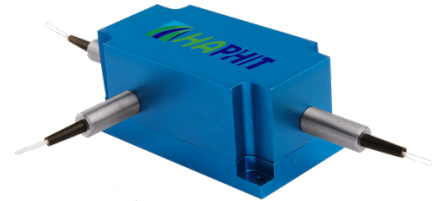

SPECIFICATIONS

Parameter	Unit	Value
Working Wavelength	nm	830+/-10, 850+/-10
Insertion Loss@23°C	(Typ.)	1.5
	(Max.)	2.0
Isolation@23°C	(Typ.)	22
	(Min.)	18
PDL	dB	≤0.2
Optical Return Loss	dB	≥45
Cross Talk	dB	≥45
Fiber Type	-	HI780 Fiber or Nufern 780HP Fiber
Fiber Tensile Load	N	5
Maximum Optical Power (CW)	W	0.3, 0.5, 1, 2, 3, 5, 10
Operating Temperature	°C	0~50
Storage Temperature	°C	-40~85

- Note:**
1. Specifications are for device without connectors; Specifications may change without notice.
 2. To add connectors, IL is 0.7dB higher, RL is 5dB lower.
 3. Only guarantee 1W continuous wave (CW) power thru testing for connectors added.
 4. Devices for higher optical power or with other type fiber or consigned fiber are also available.

PACKAGE DIMENSION

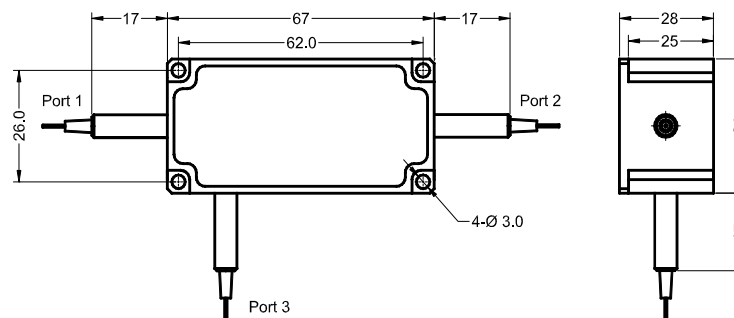

ORDERING INFORMATION (PN)

FCIR-	NNNN	-3HP	NN	- (C)	C	NN	- CC/CCC
	<i>Center Wavelength</i>		<i>Optical Power</i>	<i>Fiber Type</i>	<i>Fiber Sleeve</i>	<i>Fiber Length</i>	<i>Connector Type</i>
	830=830nm		03= 300mW	7= 780HP Fiber	B= Bare fiber	05=0.5m	N=Without Connector
	850=850nm		1= 1 Watts	Blank for HI780 Fiber	L= Loose Tube	10=1.0m	FC/APC=FC/APC Connector
			3= 3 Watts		2=2mm Cable	15=1.5m	LC/PC=LC/PC Connector
			10= 10 Watts		3=3mm Cable	20=2.0m	SC/UPC=SC/UPC Connector